

# MULLER MULES

## Volvo FM84 TR1HA Euro6

~12000

D56789

| Ente  | Rev. | Descrizione | Data     | Dis. | Qnt. | AppAO |
|---|------|-------------|----------|------|------|-------|
| MRK   | 0    | EMISSIONE   | 07/06/16 | L.B. |      |       |
| INGOMBRO - SCHEDA 54/1 - Rev. 0 - 15/12/100 |      |             |          |      |      |       |

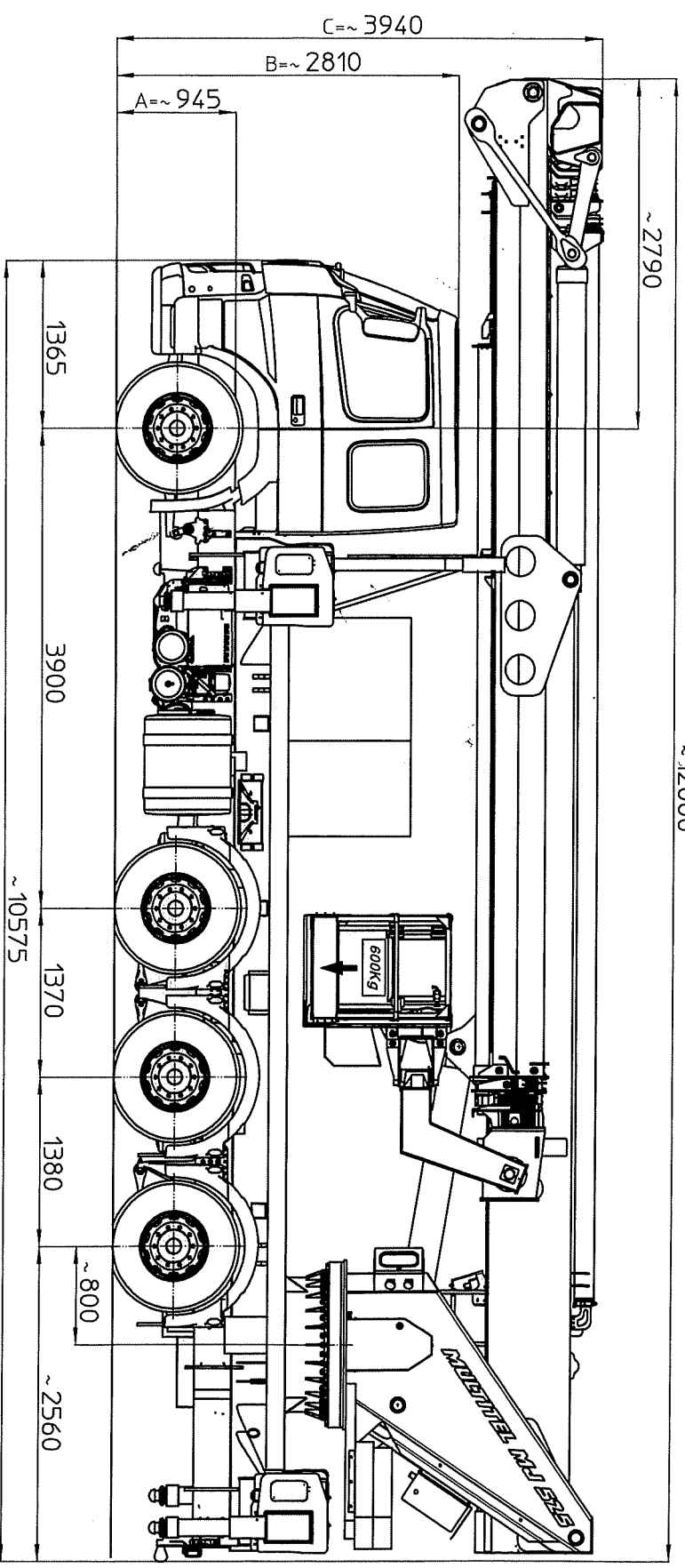

I - Le quote riportate in disegno sono indicative e possono subire variazioni. In particolare le quote A-B sono relative alle dimensioni dell'autocarro, quindi devono essere verificate sullo stesso. La quota C (altezza totale) e' subordinata alle quote A-B e non comprende eventuali parti flessibili.

F - Les cotes indiquees dans le dessin sont indicatives et peuvent subir des variations. En outre les cotes A-B sont relatives aux dimensions du porteur, donc elles doivent être vérifiées sur le porteur même. La cote C (hauteur totale) est subordonnée aux cotes A-B est indiquée hors flexibles.

E - The dimensions shown in the drawing are an indication and may undergo changes. Further the dimensions A-B are related to the truck sizes, therefore they must be verified. The dimension C (total height) is subject to A-B and does not include hoses.

D - Die Maße, die in der Zeichnung gezeigt werden, sind eine Anzeige und können Änderungen durchmachen. Die Abmessungen A-B betreffen die Fahrzeugmasse, daher sollen sie geprüft werden. Die Abmessung C (Gesamthöhe) hängt von A-B Abmessungen ab, die schlauche sind ausgeschlossen.

| STABILIZATION TYPE        | CAGE PAYLOAD (kg) |                   |       |       |
|---------------------------|-------------------|-------------------|-------|-------|
|                           | 220kg             | 280kg             | 400kg | 600kg |
| STRAIGHTLINE STAB.        |                   | D56767            |       |       |
| PARTIALLY EXTENDED STAB.  |                   | D56766            |       |       |
| TOTALLY EXTENDED STAB.    |                   | D56765            |       |       |
| UNDERBRIDGE               |                   |                   |       |       |
| REMAINING PAYLOAD DRAWING | D540K             |                   |       |       |
| CHASSIS                   | 1st AXLE          |                   |       |       |
| UNLOAD WEIGHT             | 4890 kg           | 2nd-3rd-4th AXLE  |       |       |
| MAX WEIGHT                | 9000 kg           | 9500+9500+8000 kg |       |       |
| G.V.M.                    | 36000 kg          |                   |       |       |
| NOTES:                    |                   |                   |       |       |

STABILIZZAZIONE AUTOCARRI PTT < 36 TON.  
 LARGHEZZA MASSIMA 2540mm.  
 STABILISATION VEHICULES PTAC < 36 TON.  
 LARGEUR MAXI 2540mm.  
 TRUCK STABILISATION FOR GVW < 36 TON.  
 AND MAX WIDTH 2540mm.  
 ABSTÜTZUNG FÜR FAHRZEUG MIT GES. GEWICHT < 36 TON.  
 UND MAX. BREITTE 2540mm.

D54014

| Ente                                       | Rev. | Descrizione | Data     | Dis. | Autr. | Ap.AO |
|--|------|-------------|----------|------|-------|-------|
| MRK  | 0    | EMISSIONE   | 18/06/15 | L.B. |       |       |
| INGOMBRO - SCHEDA 54/1 - Rev. 0 - 15/12/00 |      |             |          |      |       |       |

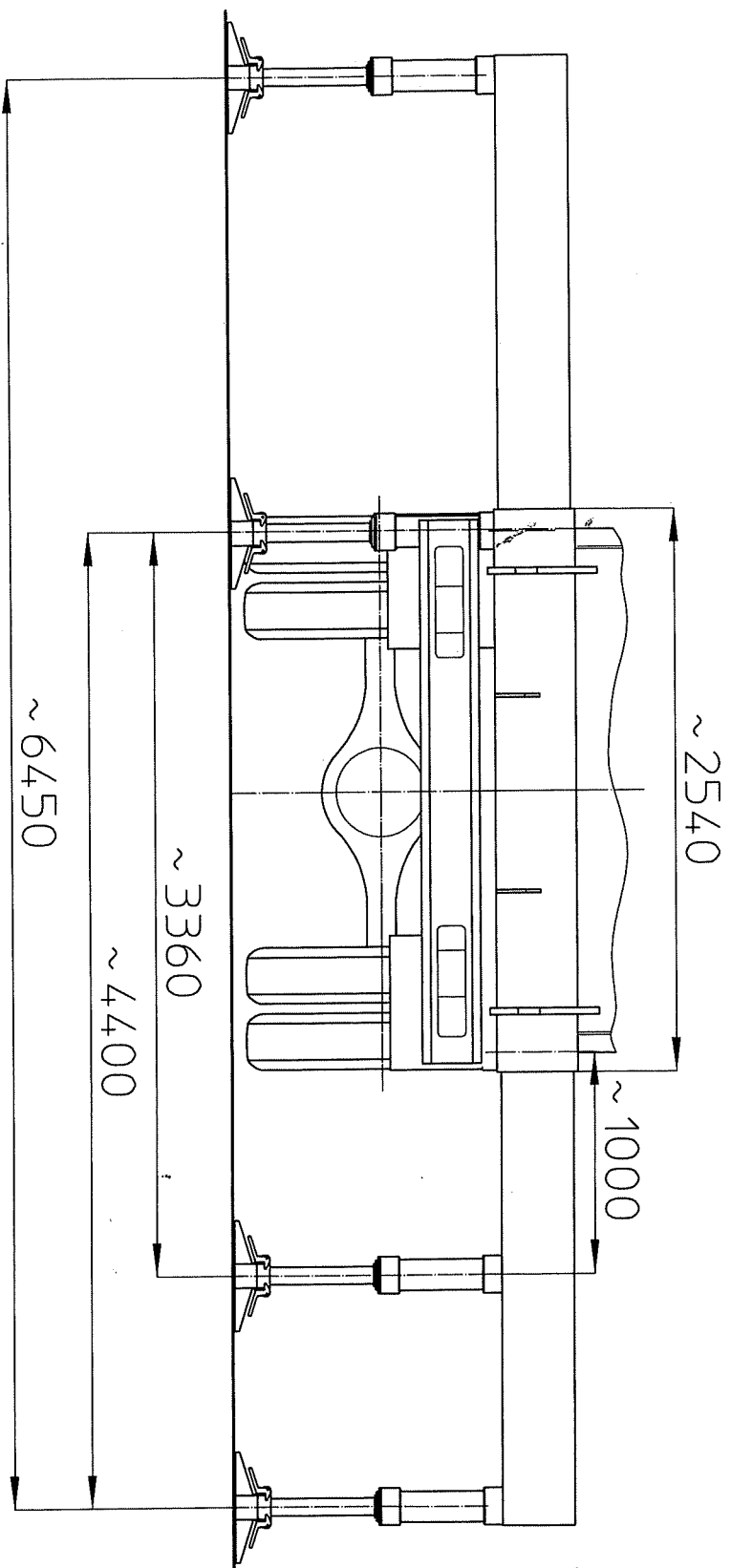

# MULTITEL MJS75

| Ente  | Rev. | Descrizione | Data     | Dis. | Contr. | Ap.AQ |
|---|------|-------------|----------|------|--------|-------|
| MRK   | 0    | EMISSIONE   | 03/06/16 | L.B. |        |       |
| DIAGRAMMA - SCHEDA 54/2 - Rev. 0 - 15/12/00 |      |             |          |      |        |       |

D56765

|                      |                                     |   |                      |            |            |            |            |
|----------------------|-------------------------------------|---|----------------------|------------|------------|------------|------------|
| P.T.T.=36000kg       | STABILIZZATORI COMPLETAMENTE ESTESI | ✓ | SBRACCIO DI LAVORO   | 28,70m ±5% | 31,40m ±5% | 33,20m ±5% | 35,90m ±5% |
| G.V.W.=36000kg       | FULLY EXTENDED STABILIZERS          |   | WORKING OUTREACH     | 28,70m ±5% | 31,40m ±5% | 33,20m ±5% | 35,90m ±5% |
| P.T.A.C.=36000kg     | STABILISATEURS COMPLETEMENT ETENDUS |   | DEPORT DE TRAVAIL    | 28,70m ±5% | 31,40m ±5% | 33,20m ±5% | 35,90m ±5% |
| GES. GEWICHT=36000kg | GANZ AUSGEFAHRENE STÜTZEN           |   | SEITLICHE REICHWEITE | 28,70m ±5% | 31,40m ±5% | 33,20m ±5% | 35,90m ±5% |

